

结构特点 Design features

- 内装、单端面、单弹簧、非平衡型、叉销或紧定螺钉传动结构，任意旋向，安装方便。
- Internally mounted, single face, single spring, unbalanced, by means of pin fork or set screw drive, any rotation direction, it can be mounted conveniently.

材料 Materials(to DIN24960)

- 旋转环 Rotary Ring: U12、U22、Q22
- 静止环 Stationary Ring: B、U12、U22、Q2、Q22、V1
- 辅助密封 Auxiliary Seal: P、E、V、M1、T1
- 弹簧及其他结构件材料 Spring and Other Parts: G、G

适用范围 Operating limits

- 压力 Pressure: 0~1.2MPa
- 温度 Temperature: -20~180°C
- 线速度 Speeds: ≤ 15m/sec

介质 Medium

油类、水、盐、非结晶性溶剂、有机溶剂及其它弱腐蚀性溶液。
Oil, water, salt, noncrystalline agent, organic solvents and other weak corrosive fluid.

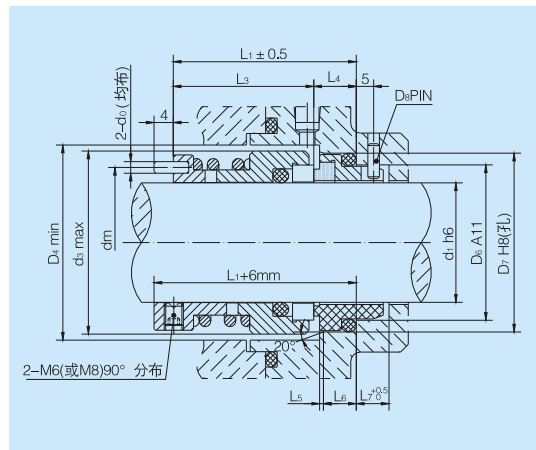

型号 Model	d1	ds	D4	D6	D7	ds	dm	do	L1	L3	L4	L5	L6	L7
CN 113-18	18	32	34	27	33	3	25.0	4	33	23.0	10.0	2.0	5	9
CN 113-20	20	34	36	29	35	3	27.0	4	33	23.0	10.0	2.0	5	9
CN 113-25	25	39	41	34	40	3	32.0	4	35	24.5	10.5	2.0	5	9
CN 113-30	30	44	46	39	45	3	37.0	4	35	24.5	10.5	2.0	5	9
CN 113-35	35	49	51	44	50	3	42.0	4	39	27.5	11.5	2.0	5	9
CN 113-40	40	56	60	51	58	4	48.5	4	44	31.0	13.0	2.0	6	9
CN 113-45	45	61	65	56	63	4	53.5	4	44	31.0	13.0	2.0	6	9
CN 113-50	50	66	70	62	70	4	58.5	5	49	35.0	14.0	2.5	6	9
CN 113-55	55	71	75	67	75	4	64.5	5	49	35.0	14.0	2.5	6	9
CN 113-60	60	80	85	72	80	4	70.0	5	60	46.0	14.0	2.5	6	9
CN 113-65	65	85	90	77	85	4	74.5	5	60	46.0	14.0	2.5	6	9